

SPC400

User's guide



ZA La Jonchère

F-74420 BOËGE

 (33) 4 50 39 08 49

 (33) 4 50 39 08 33

THE SECTIONS

THE SECTIONS	1
1. INTRODUCTION	1
2. DEFINITION AND CONFIGURATION	9
3. MEASUREMENTS AND STATISTICS	30
4. EXAMPLES OF PROBE COMBINATIONS	44
5. TABLE OF CONSTANTS AND FORMULAS	47
TABLE OF CONTENTS	51

1. INTRODUCTION

1.1 PRESENTATION OF THE SPC400	2
1.2 PRECAUTIONS	2
1.3 FEATURES.....	3
1.4 FRONT PANEL.....	4
1.5 THE KEYBOARD.....	5
1.6 THE SCREEN.....	6
1.7 THE SERIAL PORT	6
1.7.1 « SERIAL PORT » CONNECTOR PIN-OUT	6
1.7.2 THE OPTICAL READER	7
1.8 PEDAL ENTRY.....	7
1.9 STRUCTURE OF THE SPC400 SOFTWARE.....	8

1.1 PRESENTATION OF THE SPC400

The programmable multi-characteristics comparator SPC400 is a sophisticated device for dimensional control operated by a microprocessor.

A multi-characteristics system

The SPC400 can receive directly 8 inductive probes (extensible to 16 in option) and 8 digital probes or linear encoders, measure 16 characteristics that can belong to up to 16 different fixtures. Optional interfaces provide 8 additional entries for different measuring instruments (calliper, micrometer, etc..) and inputs/outputs managed by automation sequences.

A programmable calculator with a non volatile memory

The measuring setups (nominal value, master value, tolerances, formulas of probes combinations, trends, etc.), are programmed by keyboard and recorded in a non volatile memory. This enables their preservation, as well as that of the measured results, in case of a power cut.

The memory has a capacity of 4 pages, extensible to 16 pages. Each page can be split up (partitioned) into 1, 2, 4 or 8 measuring setups. By consequence, from 4 to 128 measuring setups can be recorded.

A liquid crystal graphic display

The control charts are displayed in graphic form through a liquid crystal display of 160*128 points with adjustable contrast by keyboard and back-light. In text mode, up to 16 lines of up to 20 characters can be displayed.

Automatic mastering

The SPC400 masters automatically from the values read on the standard (or master piece). The repetition an stand-by position tests, and an imposed periodic mastering depending the on time passed or of the number of parts measured, can be rendered compulsory.

1.2 PRECAUTIONS

- Read this manual thoroughly before using the device
- Do not expose the device to excessive temperature (more than 35°C)
- Do not use solvents when cleaning it
- Do not expose the LCD display to direct sun-light (its life-time will be shortened)
- Never connect or disconnect a measuring instrument or a digital probe before switching off the SPC400.

1.3 FEATURES

- 8 standardised entries for inductive probes (73,75 mV/V/mm on 2 k Ω).

Precision : +/- 1% .

Automatic selection of measuring range :

- ◇ $\pm 2000 \mu\text{m}$ / resolution $1 \mu\text{m}$ if display ≤ 3 decimals
- ◇ $\pm 200 \mu\text{m}$ / resolution $0.1 \mu\text{m}$ if display = 4 decimals.

- 8 optional entries for Mitutoyo instruments
- 8 optional universal entries for instruments of different manufacturers (calliper, micrometer, scales, etc.).
- Orbit bus (RS485) for 8 digital probes or linear encoders.
- 16 characteristics belonging to up to 16 different fixtures for the measurement of a same part.
- Optional 'Input/output boards' (maxi 16 inputs/16 outputs) for automation programming.
- Liquid crystal display with back-light of 16 lines * 20 characters in text mode and 128*160 points in graphic mode, with contrast adjustment by keyboard.
- Real time clock and watch dog.
- 4 pages of memory for 4 to 32 setups, extensible to 16 pages (max. 128 setups).
- 24-key alpha-numerical tactile keyboard.
- 1 serial port (RS232 and RS485) for printer, external computer, bar-code reader or for running in network (in option).
- 1 buzzer for indicating erroneous manipulations.
- Temperature of operation : +15°C to +30°C
- Temperature sensitivity in dimensional control : 0,02% per °C
- Maximum relative humidity : 80%
- Dimensions : width 290 mm, height 117 mm, depth 175 mm.
- Weight 1900 grams.
- Power supply : 220 V or 110 V, +/- 10%
- Maximum power consumption: 15 VA

1.4 FRONT PANEL

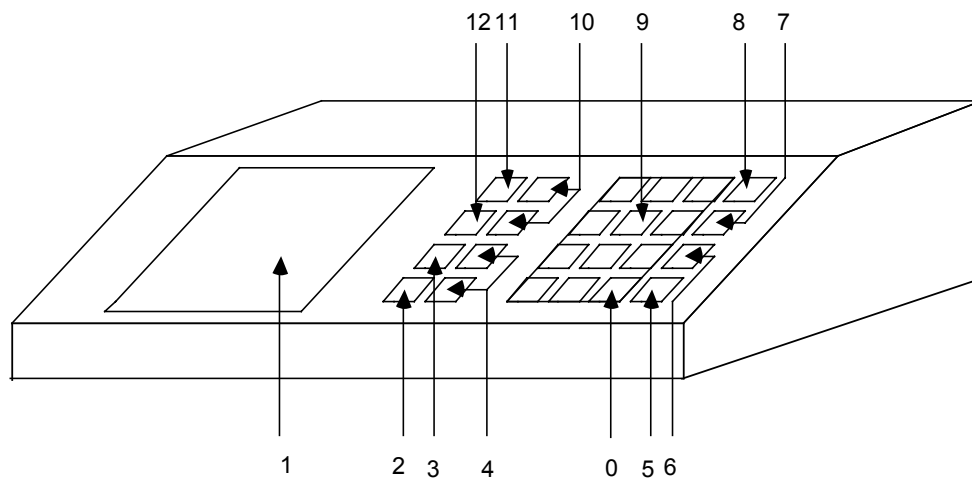



Fig. 1

0 = "return"-key 

1 = liquid crystal display

2 = "measure"-key 

3 = "exit"-key 

4 = keys « page up »  and « page down » 



5 = "shift"-key 

6 = command for transfer to serial port 

7 = print command 

8 = key for selection of numerical / alphabetical mode 

9 = block of numerical keys

10 = "line up, line down"-keys  

11 = key for "deletion of a value" 

12 = key for "erasure of a character" 



1.5 THE KEYBOARD

All commands are entered by the keyboard, which is why you have to know the keyboard in detail.

The keyboard is composed of 24 keys, forming two blocks:



- numerical keys (16 keys), concern acquisition
- command and edition keys (8 keys).



Each key can have up to three different functions :

- The first one is represented in the centre of each key. The access of this function is direct.
- The second function is represented on the lower part of each key. To obtain this function, press simultaneously the "shift"-key  (5 on figure 1) and the desired key.
- The third function is the alphabetical entry. To select alphabetical / numerical entry, use the "alpha"-key  (8 on figure 1). The LED on the key will light to indicate the alphabetical mode. To return to numerical mode, press the "alpha"-key once again. The "shift"-key can be used in alphabetical as well as in numerical mode.

The numerical block has the form of a calculator keyboard. It enables the acquisition of controlled parameters and the selection of options in menus. Each entry has to be validated by pressing the "return"-key .

Six keys for moving around on the screen and managing the edition :

The keys   (10 on figure 1) allow you to move up or down, line by line during edition or in the menus. During display of statistics of a characteristic, they allow you to move from one screen to another.

The keys   (4 on figure 1) allow you to move up or down, page by page, during edition. During display of statistics, they allow you to move from one characteristic to another.

The key  (11 on figure 1) erases a value to allow its modification.

The key  (12 on figure 1) erases one by one the characters on the line of entry.





The command  (7 on figure 1) enables the printout of measurements and statistics on a printer.

The command  (6 on figure 1) enables the transfer of results by the serial interface.

The key  (2 on figure 1) enables the measurement reading. If dynamic measurement has been defined in the setup, a red LED will light, to indicate dynamic measurement in progress. To end the dynamic measurement, press the key once again. If the entry option for measuring instruments is present, the LED will light during measurement by an instrument.

1.6 THE SCREEN

The LCD screen has a contrast adjustment by keyboard.

The contrast is adjusted by the keys   and   in all the menus displaying 'date/time' and selections.

1.7 THE SERIAL PORT

SPC400 has a serial port, marked , on its back panel. This port enables the connection of a serial printer. The printer must use the extended set of characters of IBM printers. This port also enables the running in a network or the transfer of measurements to a PC or similar appliances. It can be used as RS232, RS485 and current loop. In a disturbed environment, it's advisable to use the "current loop"-connection.

You can choose to replace the current loop with an output « status of the part » (opto isolated).

The transfer format is the following : 1 start bit, 8 data bits, 1 stop bit, no parity.

The baud rate can be adjusted by the user (see chapter 2.4.4 Configure)

The handshaking is controlled by the XOn/XOff protocol.

1.7.1 « SERIAL PORT » CONNECTOR PIN-OUT

It is equipped with a female Sub D 9 pin-plug.

Description of signals and assignment of pins.

<i>Pin</i>	<i>Signal</i>	<i>Direction</i>	<i>Description</i>
1			Not used
2	RX	I	Reception RS232
3	TX	O	Transfer RS232
4	DTR	O	Positive signal through 5 kΩ
5	Gnd	-	Ground
6	A	IO	Reception/transfer RS485
7	B	IO	Reception/transfer RS485
8	CLhi	IO	Input of the current loop (or status output)
9	CLlo	O	Output of the current loop (or status output)

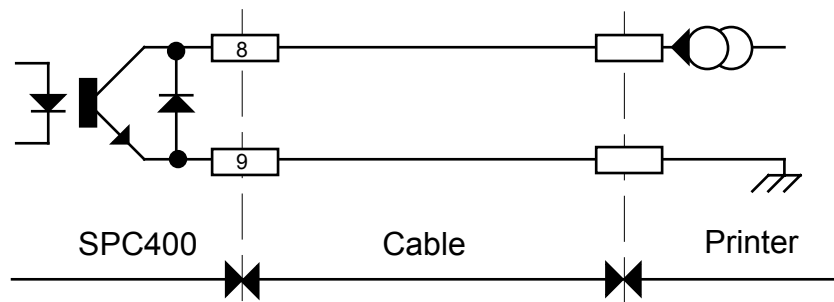
 Connection of the **current loop**

1.7.2 THE OPTICAL READER

An optional adapted bar-code optical reader can be connected to SPC400. It can be used for fast input of setups.

Use :

The reader must be kept like a pen, with an angle of 15° to 30°. It can be put to anyone of the 2 sides of the bar-code to read. Pressing slightly, move the reader with a regular movement, like drawing a line. A fast movement gives better results. A sound indicates a good reading of the bar-code. The information is immediately displayed.

Note : Many kinds of bar-codes can be read with the optical reader. They are generally printed with a personal computer with an adapted software. The code « 128B » is better because it has capitals and lower case letters (without accent), mathematical symbols and numbers.

1.8 PEDAL ENTRY

On the back panel, a 5-pin DIN plug enables the connection of a command pedal.

The command pedal does the same functions as the  key, and can be used for I/O controls.

<i>Pin</i>	<i>Signal</i>	<i>Description</i>
1	opto C	cathode of the opto-coupled entry
2	ground	
3	nc	
4	opto A	anode of the opto-coupled entry
5	+ 5V	+ 5 Volts through 100 Ω

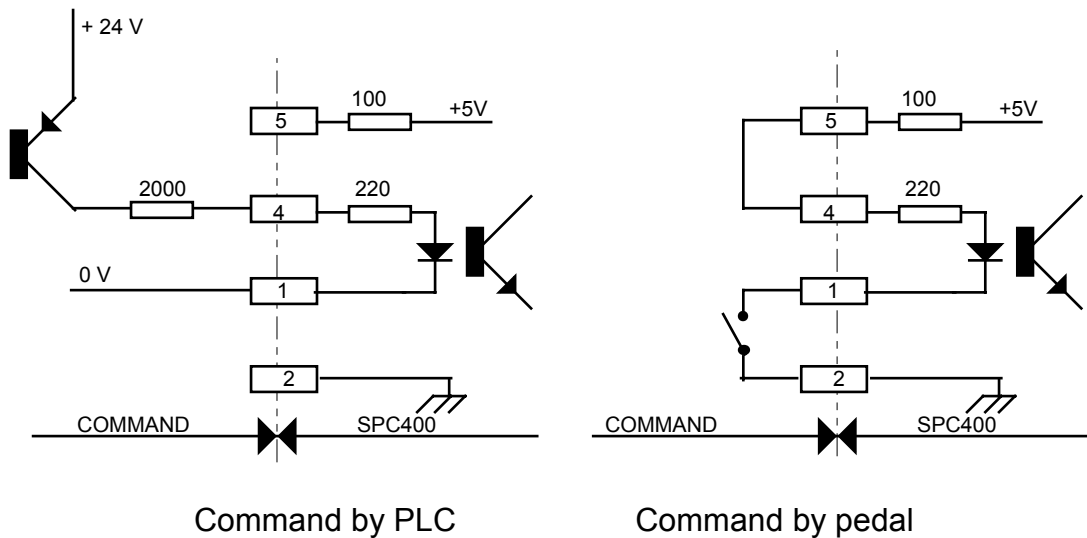

1.9 STRUCTURE OF THE SPC400 SOFTWARE

SPC400 software is organised around two principal modules :

- 1) the **definition and configuration**-module.
Allows the user to enter, modify and print out setups, configure the serial port, select the language to be used, partition memory pages and master probes.
- 2) the **measurements and statistics**-module.
Allows the user to measure, display and print out results and display and print out statistics, adjust probes and master probes.

Every time the SPC400 is switched on, you will find yourself in the module which was used at the time of the switch-off.

To move from the **definition and configuration**-module to the **measurements and statistics**-module, use the function 3 of the menu:

3 : MEASUREMENT MENU

To move from the **measurements and statistics**-module to the **definition and configuration**-module, use the function 6 of the menu:

6 : INITIALISE, then
2 : DEFINITION, then
PASSWORD : « DEF »

Note: The access code is supposed to be known only by the foreman to avoid the risk that the person performing the measurements modifies the parameters of a setup.

2. DEFINITION AND CONFIGURATION

The **definition and configuration**-module allows the user to enter, modify and print setups and to set the clock. It also allows to select the language to be used, configure the printer port and partition memory pages.

This module is organised around a main menu :

2.1 DEFINE.....	10
2.1.1 GENERAL DEFINITION SCREEN.....	11
2.1.2 SELECT OPTIONS (1).....	12
2.1.3 DEFINITION OF VIOLATIONS.....	12
2.1.4 CHARACTERISTICS DEFINITION.....	13
2.1.5 SELECT OPTIONS (2).....	18
2.1.6 MASTER READING	18
2.1.7 DEFINITION - NBR OF FIXTURES.....	20
2.1.8 AUTOMATION SEQUENCES	20
2.1.9 MEASUREMENT TRIGGER.....	20
2.1.10 IDENTIFICATION OF DIGITAL PROBES.....	22
2.2 CATALOGUE.....	23
2.2.1 SELECT	23
2.2.2 PRINT	23
2.2.3 DUPLICATE	24
2.2.4 DELETE	24
2.2.5 IMPORT-EXPORT.....	24
2.3 MEASUREMENT MENU	25
2.4 CONFIGURATION 1.....	26
2.4.1 CLOCK SETTING.....	26
2.4.2 SELECT LANGUAGE.....	26
2.4.3 SERIAL PORT.....	26
2.4.4 PARTITION	27
2.5 CONFIGURATION 2.....	28
2.5.1 PROBE TEST.....	28
2.5.2 GRAPHIC MODE	28
2.5.3 PASSWORD	28

2.1 DEFINE

14 / 09 / 1999
15 : 12 : 10

1 : DEFINE

2 : CATALOGUE

3 : MEASUREM. MENU

4 : CONFIGURATION 1

5 : CONFIGURATION 2

6 : MASTER READING

PART'S REFERENCE :







Note : Whenever possible, an help line is displayed concerning available options on the bottom of the screen.

The "define"-function allows you to enter a new setup or modify an existing setup. The definition will concern the currently selected setup.

Important : *before* entering a definition, make sure the partition of the memory corresponds to your needs (see chapter 3.6 Configure).



You have the possibility of changing the selected page with the catalogue-function (see chapter 3.4 Catalogue).

Key legend:

- 

: moves to the following or preceding screen
- 

: moves the cursor on a screen from one item to another
- 
: modifies a value character by character
- 
: erases the line of entry completely, to enable a new entry
- 
: exits from definition

2.1.1 GENERAL DEFINITION SCREEN

PRINTOUT HEADING

The head-line is an alphanumerical text of a maximum of 19 characters which appears in expanded characters on the head-line of printed documents. The head-line may contain the name of your department or company. To obtain a neat layout, it is advisable to centre the text by inserting space characters before the entered text ( ).

PART'S REFERENCE

This alphanumerical text of a maximum of 19 characters appears in the catalogue and at the bottom of the menus. It allows the identification of the setup.

STATISTICS

Two types of statistical calculations can be performed :

« **MACHINE** » *statistics* : Enables the analysis, for a short period of time, of dispersions due to the machine. At least 50 consecutive parts are measured. The statistics by characteristic provides the following indications:

- AVERAGE
- STANDARD DEVIATION
- Cm (machine capability).
- Cmk (capability taking into account the position of the average)
- PERCENTAGE of rejected parts concerning a particular characteristic
- encountered MAXIMUM AND MINIMUM values
- RANGE (max-min)
- HISTOGRAM
- CONTROL CHARTS OF INDIVIDUAL VALUES
- PROBABILITY PLOT
- PARETO ANALYSIS (in case of value(s) beyond tolerances)

« **PROCESS** » *statistics* : Enables the analysis of the manufacturing process. The manufacturing is monitored during a period of time sufficiently long for detecting dispersions caused by :

- the MACHINE
- the INPUT MATERIAL
- the LABOUR
- the METHOD used
- the ENVIRONMENT

2 to 25 parts are sampled at a specific time interval. The statistics by characteristic provide the following indications:

- CONTROL CHART OF AVERAGES
- CONTROL CHART OF STANDARD DEVIATIONS or RANGES
- CONTROL CHART OF AVERAGES and 6σ or RANGES
- CONTROL LIMITS
- Cp (process capability index)
- Cpk (capability index taking into account the centring of the process).

Note : if you choose process statistics, you have the possibility of considering all measured parts as belonging to a same sample and perform the statistical calculation for the machine.

If process statistics is selected, the number of parts per sample must be indicated (2 to 25).

The SPC400 provides the choice between calculated or imposed control limits. Indicate your choice by the keys [1] or [2].

You also have to choose between a display of standard deviation or range chart, again you use the keys [1] or [2].

You have also specify (using the keys [1] or [2]) whether you wish to display mixed charts (control charts displaying averages and 6s or averages and ranges).

At last, you can define a number of pieces between each sample. This value will be between 0 (following samples) and less than 65000.

2.1.2 SELECT OPTIONS (1)

UNIT

The units of measure used by SPC400 are either millimetres or inches. You indicate your choice by the [1] and [2]-keys.

DECIMALS

You can choose the number of decimals to be displayed on the screen and printed out on documents.

Note:

- *The number of decimals displayed has no incidence on the precision of the calculations, which are always performed with full precision.*

- *For characteristics measured by inductive probes, the selected precision automatically induces the resolution and the measuring range for these probes :*

± 2000 µm / resolution 1µm if display ≤ 3 decimals

± 200 µm / resolution 0.1µm if display = 4 decimals.

- *In all cases, the results from the statistical calculations are displayed with one additional decimal.*

NUMBER OF CHARACTERISTICS

Measurement setups can include up to 16 characteristics.

PRODUCTION

In statistics 'machine' or 'none', the validation of this option allows the software to manage the production events (stop or event codes, events record, ..).

If this option is set, it's necessary to input the max time between two measurements. This time (maxi 1 hour) is used by the SPC400 to know if the production is stopped or not, and then to record the stops and beginnings of the production.

2.1.3 DEFINITION OF VIOLATIONS

Four controls of *violations (trends)*,

in « process » statistics, on averages and standard deviations (or ranges), giving eight types all together, can be individually ON or OFF by YES or NO :

- one single point out of limits
- N consecutive points (7 by default) in a regular ascending or descending progression (RUN)
 - ◊ parameter « SAMPLES 'TREND' » between 2 and 20
- N consecutive points (7 by default) the same side as the central value (SHIFT)
 - ◊ same parameter « SAMPLES 'TREND' » between 2 and 20
- Less than P1 % (default 40 %) or more than P2 % (default 90 %) of points on the NT last points in the central third (between -1σ and $+1\sigma$) which theoretically includes 68,26 % of the points for a normal distribution
 - ◊ P1 = parameter « '1/3 C' LIMIT:< » lower than 68 %
 - ◊ P2 = parameter « '1/3 C' LIMIT:> » included between 68 and 100 %
 - ◊ NT = parameter « '1/3 C' SAMPLES » included between 15 and 50

Each violation will be detected lower (symbol '▼') or upper (symbol '▲') for each type.

2.1.4 CHARACTERISTICS DEFINITION

Two successive screens allow the setting of parameters for each characteristic. In the first screen, you define the origin and the type of measurement for each characteristic :

ORIGIN

Defines the acquisition mode for the characteristic :

- Origin = 0 for inductive probes and digital probes or linear encoders
- Origin = 1-8 for measuring instruments (if this option is available)

Note : the same instrument can be used in several characteristics

- Origin = 9 for measurements entered by keyboard
- Origin = 10 already calculated values or available characteristics.

Note : the help function at the bottom of the screen will only display the authorised origins according to the options present in your SPC400.



TYPE OF MEASUREMENT

When using inductive probes, digital probes, linear encoders or combinations of characteristics, several types of calculations may be performed :

0 = STATIC : this is the most common case, the part is fixed and the measurement is made by only one reading.

1 = MAX-MIN : as for the following three types of measurements, two different cases can be encountered :

- 1) ORIGIN = INDUCTIVE or DIGITAL probes (0) :

This is a dynamic measurement. When you press the -key for measurement, the Led lights indicating that the reading is in progress for the corresponding probes. To end the measurement, press the -key once again. The result displayed will be the difference between the maximum and minimum values encountered. For this type of measurement, only the maximum tolerance will be requested, the nominal value and the minimum tolerance being considered as equal to zero.

2) OTHER ORIGIN (1 to 8, 9, 10) : This is a static measurement. The SPC400 performs a calculation on a series of results (Ex. MAX-MIN on a series of probes or on a series of measurements) (see chapter 2.1.3 CHARACTERISTICS DEFINITION).

2 = AVERAGE : If it is a dynamic characteristic, the result is the average of the encountered measurements (sum of measured values / n). If it is a static characteristic, it is the average of a series of measurements or probes.

3 = MEDIAN : If it is a dynamic characteristic, the result is the average of the maximum and minimum values encountered $((\text{max}+\text{min})/2)$. If it is a static characteristic, it is the median of a series of measurements or probes.

4 = MAX : If it is a dynamic characteristic, the result is the maximum value encountered. If it is a static characteristic, it is the maximum value of a series of measurements or probes.

5 = MIN : If it is a dynamic characteristic, the result is the minimum value encountered. If it is a static characteristic, it is the minimum value of a series of measurements or probes.

« INTERRUPTED » MODE IN DYNAMIC MEASUREMENT

For a characteristic with origin « probes » and a type of dynamic measurement, it is possible to select the standard dynamic mode or one of the two interrupted dynamic modes : maxi or mini.

In these two modes, only the maxi or mini inflection points are kept as measures. So the dynamic measurement won't be continuous, but interrupted by the detection of inflection points.

A maxi inflection point is detected if the measurement decreases of the threshold value (which can be setup) after a maxi. A mini inflection point is detected if the measurement increases of the threshold value (which can be setup) after a mini.

TYPE OF SAVING FOR CHARACTERISTICS

Each characteristic can be set as :

- « *intermediary* » : yes = measures not saved and not in statistics calculations
The intermediary characteristics aren't in the screens and print out for results.

- « *in stat.* » : no = measures saved and not in statistics calculations

In the second screen are entered, for each characteristic : designation, nominal value, master value, maximum and minimum tolerances and the calculation to be performed :

DESIGNATION

The designation of the characteristic in alphanumerical text containing a maximum of 19 characters.

NOMINAL VALUE

The nominal value, i.e. theoretic value, expressed in millimetres or in inches.

MASTER

The master value will be the reference for measurements performed by inductive probes, digital probes and linear encoders.

MAXIMUM TOLERANCE

The maximum tolerance entered as a gap (Ex. 0,02 and not 10.02 if 10.0 is the nominal value).

MINIMUM TOLERANCE

The minimum tolerance entered as a gap (Ex. -0,02 and not 9.98 if 10.0 is the nominal value).

CALCULATION

This is a mathematical expression of a maximum of 39 characters defining the combination of probe readings and calculations needed for each characteristic (see chapter 4. Examples of probes combinations).

The SPC400 has 5 types of data entry.

Variables to be used according to the source of measurement :

- inductive measurement: **C(n)** where 'n' is the number of the probe ($1 \leq n \leq 16$)
- digital probes:
or linear encoders : **S(n)** where 'n' is the number of the probe ($1 \leq n \leq 8$)
- measuring instruments: **I(n)** where 'n' ($1 \leq n \leq 8$) is the number of the characteristic and not instrument can be used for the reading of several characteristics. The number of the instrument is already defined for each characteristic in the origin parameter.
- keyboard acquisition: **K(n)** where 'n' is the number of the characteristic ($1 \leq n \leq 16$)
- other characteristic: **M(n)** where 'n' is the number of the other characteristic (result of an already calculated characteristic) ($1 \leq n \leq 15$)

Notes :

Measurements of different origin can be used in the calculations :

- For characteristics measured by inductive or digital probes, variables C() and S() can be used.
- For characteristics measured by instruments, variables C(), S() et I() can be used.
- For characteristics entered by keyboard, variables C(), S(), I() et K() can be used.
- For characteristics based on other characteristics, variables C(), S(), I(), K(), M(), or only one table of variables C(x..y), S(x..y), I(x..y), K(x..y), M(x..y) can be used. «x" and "y" represent the first and the last member of the table. In an M(x..y) table, «x" and "y" must be less than the characteristics number for which the calculations are to be performed. For example, for characteristic 5, "x" and "y" cannot exceed 4.

The sequence of calculation is as follows:

- characteristics measured by inductive and digital probes or linear encoders (origin=0)
- then characteristics measured by instruments ($1 \leq \text{origin} \leq 8$).
- then characteristics entered by keyboard (origin=9).
- at last, characteristics calculated with other characteristics (origin=10).

For each origin, calculations are made in chronological order (i.e. characteristic 1 then 2 etc.).

OPERATORS

The following operators are allowed in the calculations : + - * / ()

As well as:

SIN (x)	= sine of x
COS (x)	= cosine of x
TAN (x)	= tangent of x
ASIN (x)	= arc sinus of x
ATAN (x)	= arc tangent of x
SQR (x)	= square root of x
EXP(x)	= raises the number e (2,7182818) to the power of the argument x
y ** x	= raises y to the power x
LN (x)	= natural logarithm of x
LOG (x)	= 10 base logarithm of x
ABS (x)	= absolute value of x
PI	= 3,1415926
RD	= coefficient of conversion from radians → degrees (180/PI)
DR	= coefficient of conversion from degrees → radians (PI/180)

- For trigonometric functions, "x" is expressed in radians
- You have the possibility of using integer or real coefficients, which can be expressed as scientific expression (Ex. 2.2E-6 for 0.0000022).
- We recommend not to use a trigonometric function directly on the value provided by an inductive probe. E. g. ABS(C(1)).

PRECEDENCE OF OPERATORS

The hierarchy of operators in calculations is as follows :

- 1 parentheses ()
- 2 EX (x)

- 3 negation -
- 4 multiplication and division * /
- 5 addition and subtraction + -

For calculations on tables of values (ORIGIN 10, TYPE 1 to 5) allowed operators are :

- **C (x..y)** = performs the calculations for the table of inductive probes x through y
- **I (x..y)** = performs the calculations for the table of instruments x through y
- **S (x..y)** = performs the calculations for the table of digital probes x through y
- **K (x..y)** = performs the calculations for the table of keyboard entries x through y
- **M (x..y)** = performs the calculations for the table of characteristics x through y

ERROR CODES

The SPC400 monitors the validity of the calculation requested. In case of error, the code corresponding to the detected error is displayed :

Syntax errors :

- 1 one or more opening parentheses missing. Ex. COS (25*C(2)+5))
- 2 one or more closing parentheses missing. Ex. COS (25*C(2)+5
- 3 one or more non useful letters. Ex. C(5)-COS2/pi
- 4 writing error concerning an exponent. Ex. -25E++5 or 5.E2
- 5 one or more operations missing. Ex. C(2)5 or C(1)C(2)
- 6 one or more functions without argument. Ex. COS() or C()
- 7 one or more operations without argument. Ex. C(2)+ or S(21)--C(5)
- 8 incorrect use of a table of variables (more than one table declared or use of a table in an operation) Ex. C(2..5)+I(1..3) or COS(1..2)
Note : the - sign is authorised before a table of variables
- 9 non integer value in a table of variables. Ex. C(+1.2) or I(1E2)

Calculation impossible :

- 20 inconsistent argument Ex. C(0), K(20)
- 21 1st term of a table of variables exceeds or equals the second Ex. S(12..3)

Combination to be reconsidered :

- 30 when using inductive or digital probes (origin 0), only C() and S()-tables of variables are authorised. Ex. I(2)
- 31 when using measuring instruments (origin 1 to 8), only C(), S() and i()-tables are authorised.
- 32 when entering by keyboard (origin 9), no tables of variables can be used. E. g. : C(1..5)
- 33 when using other characteristic for a dynamic measurement (origin 10, type of measurement >0), the use of tables of variables is compulsory. (i. e. C(1) cannot be used, while C(1..3) can)

Module not available :

- 40 the module for inductive probes is absent, a characteristic can't contain a C()
- 41 the module for measuring instruments is absent, a characteristic can't contain I()

42 the module for digital probes is absent, a characteristic can't contain S().

2.1.5 SELECT OPTIONS (2)

PRINTOUT MODE

[1] ON REQUEST : It's the user who prints out the results of the measurements of a part by the function key .

[2] AUTOMATICALLY : After each measured part, the result will be printed out automatically.

Note : the functions "automatic printout" and "automatic transfer" use the same serial port, consequently, they can't be authorised simultaneously.

TRANSFER MODE

[1] ON REQUEST : It's the user who transfers the results of the measurements of a part by the function key .

[2] AUTOMATICALLY : After each measured part, in 'non network' version, the result will be transferred automatically on the serial port. In 'network' version and in 'process' statistics, an automatic export will be asked by the SPC400 to the server at the end of each sample.

Use the [1] and [2]-keys to indicate your choice.

THE CLASSES

With the SPC400, you can sort out parts by class.

In order to do this, you have to define the number of classes (up to 8) and the characteristic you will carry out the sorting on.

If the user wants to use N classes, he will have to define the upper limits of the classes from 1 to N (decreasing values from 1 to N) and the lower limit of the class N, as well as a message for each class (8 digits maxi).

In that case, at each measurement (acquisition or instantaneous page preview), the class (number and message) will be displayed at the same time as the value.

2.1.6 MASTER READING

If the setup includes measurements by inductive and digital probes, you have to indicate the desired operation mode for mastering :

STAND BY

The stand by test makes sure the probes are in the right position and are functioning correctly. After the master reading, a measurement is made in probe's stand by position (the master being removed).

This test must reveal a difference with regard to the master reading, the minimum value of this difference is set here. If you do not wish this test, enter 0.

REPETITION

This test determines the validity of the positioning of the master and the state of the reading fixture. For this purpose, a second reading with the master is made to make sure the two readings do not reveal a difference greater than the repetition value (in percent of tolerance interval).

This value is a percentage (maxi 25 %) of the limits of tolerance : so the repetition value is different for each characteristic.

If you do not wish this test, enter 0.

Note : to improve the reliability of your mastering, we recommend the validation of the two tests above : stand by and repetition. These tests oblige the user to remove the master (standard) between the two readings, which ensures the validity of the mastering.

MASTER READING

MASTER READING or CONTROL : The function 'Master reading' of the menu 'Initialise' will active 'master reading' or ' master reading control' according to your choice.

It's possible to do a master reading in the menu 'Definition' (function 6).

ON REQUEST : The operator chooses the time for the mastering by selecting this function in from the menu. Only the very first mastering following the definition of a setup is requested by the SPC400.

AUTOMATIC : The SPC400 monitors two parameters : the time and the number of measurements made since the last master reading. The first of the two parameters to exceed the indicated value will trigger a request for master reading.

Note : Each time numerical values are modified in the setup, the master reading and the statistics are cancelled.

If you choose automatic master reading, time and number of measurements between two master readings must be indicated.

MAX TIME

Maximum time allowed between two master readings (maximum 99h 59min).

NBR OF MEASUREMENTS

Maximum number of allowed measurements between two master readings (maximum 32000 measurements).

2.1.7 DEFINITION - NBR OF FIXTURES

This screen requires you to enter the number of fixtures (from 1 to 16) including inductive and (or) digital probes. This parameter reflects the number of stages necessary for complete inspection of one part.

If this number is greater than 1, you will indicate, for each fixture, the first and the last of the characteristics measured on the corresponding fixture.

2.1.8 AUTOMATION SEQUENCES

The following automation sequences can be defined :

- 16 sequences « APn » executed before the measurement of each fixture
- 16 sequences « PPN » executed while the measurement of each fixture (if dynamic characteristics are defined)
- 1 sequence « FP » executed at the end of the measurement of fixtures.

Consult the specific user's guide.

2.1.9 MEASUREMENT TRIGGER

Depending of the type of chosen statistics, the measurements will be triggered of several different ways :



- « **footswitch** » : trigger with the ME-key or the pedal, followed by a programmable delay between 0 and 30.0 seconds.
- « **range/char.** » : automatic trigger if a characteristic is in a range of programmable values, followed by a programmable delay between 0 and 30.0 seconds.

In this mode, a triggering characteristic must be defined for each fixture, with the minimum and maximum of the range.

In this mode, a measurement starts with the ME-key or the pedal. As soon as the value of the characteristic will stabilise in the range, the measure of the fixture will be done after the delay.

- « **cyclic delay** » : only in statistics « machine », cyclic trigger with a programmable delay from 3 seconds to 10 hours.



In this mode, the measurements will begin with the ME-key (or the pedal). Then, between each measurement, it's possible to use all the functions of the menus of the measurement module. All function will be automatically stopped by the following measurement.

A character  (hourglass) will indicate this mode in all the screens. The measurement cycle will be stopped with the 'Shift ME'-key ( ).

- « **cycl.d.+ftsw** » : only in statistics « machine », cyclic trigger with a programmable delay from 3 seconds to 10 hours, then valid with the pedal.

In this mode, the measurements will begin with the ME-key (or the pedal). Each measurement, after the delay, will have to be validate by the input 'pedal' (footswitch or PLC).

Then, between each measurement, it's possible to use all the functions of the menus of the measurement module. All function will be automatically stopped by the following measurement.

A character  (hourglass) will indicate this mode in all the screens. The measurement cycle will be stopped with the 'Shift ME'-key ( .

- « I/O control » : triggering of fixture measurement by automation sequences defined by an easy programming language.

This mode is not authorised for characteristics with instruments in mode 'by instrument'.

In this mode, a triggering characteristic can be defined for each fixture, with the minimum and maximum of the range. The state bits X2 and X3 (see § 2.1.8) will be processed by these values.



The measurement by « I/O control » will be indicated in all screens by a sign $\frac{1}{6}$.

2.1.10 IDENTIFICATION OF DIGITAL PROBES

If your setup includes digital probes (type DP) and (or) linear encoders (type LE), these are connected to the Orbit bus. They have to be identified individually.



If the probe is connected, an automatic identification will be done by moving the head tip of more than 1% of its measurement range. Then the number of the last probe moved appears on the screen.

It's also possible, for each probe, to input the identification number with the keyboard.

Validate by "return" . For each fixture, go on to the next probe by  and/or return to the preceding fixture by .

The SPC400 has, according to your needs, a special function to reference the linear encoders (which then transmit 0 with their tip out and the maximum of the range with their tip in). If this function is selected, at power on, the SPC400 will display, one by one, the identification numbers of the defined linear encoders, and the user will have to move in the tip of each probe to reference it.

The -key is used to activate or no this function (display of « REF.LINEAR ENCODER » : YES or NO).

Go on to the next fixture by  and/or return to the preceding fixture by .

You have now completed the definition and configuration. To return to the menu use the "exit"-key.



2.2 CATALOGUE

The catalogue function provides access to the following menu :

10 / 01 / 1998
11 : 24 : 35

1 = SELECT
 2 = PRINT
 3 = DUPLICATE
 4 = DELETE
 5 = IMPORT-EXPORT
6 = PRECEDING MENU

PART'S REFERENCE :

This menu allows to select a setup or a free memory space for the entry of a new setup, print out the selected setup, duplicate, delete a setup or perform loading operations with another SPC400 or a PC. To access the different options, place the selection bar on the desired option using the [1] through [6]-key or the  -keys. Validate your choice by .

2.2.1 SELECT

The setups (nominal values, master value, tolerances, combination formulas for probes, etc.), as well as the results of measurements, are recorded in the pages of a non volatile RAM. This memory has a capacity of 4 pages, extensible to 16. Every page can be apportioned into 1, 2, 4 or 8 setups.

To define a setup, a page has to be selected first, and then a setup in the catalogue.

The page is selected by the arrow-keys  , and the setup by the number-keys or  , followed by a validation by .

The key  enables the printout of the selected setup.

The SPC400 exists in a version 'network' to connect to an external server computer up to 99 SPC400 on a same RS485 line. In this version, a new line «  IMPORT » can appear at the bottom of the screen to call a distant on the server computer.

2.2.2 PRINT



Printout of the list of available setups (useful in the case of an extended memory).

2.2.3 DUPLICATE

This function is only available if the SPC400 is equipped with more than one page of memory. It allows to duplicate an existing setup. The setup to be duplicated has to be selected as well as the destination setup. The selection is validated by . This function allows the rapid creation of a setup that has much in common with an existing setup, or the temporary recording of statistics.

Note : If the memory size of the destination setup is greater than or equal to the source setup (see 2.4.5 Partition), the setup will be duplicated with its statistics ; in the opposite case, only the definition will be duplicated and the statistics will be lost.

2.2.4 DELETE

Displays the catalogue and allows the deletion of the selected setups with the arrow-keys  . A confirmation is requested to avoid erroneous manipulations. Confirm by 'O' (for OK) in alpha-mode.

2.2.5 IMPORT-EXPORT

This function opens a sub-menu enabling the export of data in direction of a personal computer or of another SPC400 [1], or the import of data from a personal computer or from another SPC400 [2].

The two appliances have to be connected by means of an adapted cable.

2.2.5.1 EXPORT

Export of data by SPC400 implies the transfer of the full contents of the setup : definition, measures and, when involved, readings, dates, corrective actions, causes of intervention, trends, etc. You thus have the possibility of recording a setup on the PC and re-import it later, retaking the statistics at the same point.

The active setup is transferred to a PC or to another SPC400.

If a transfer has to be done between the SPC400 and a PC, the XGammes software or an adapted software has to be used on the PC. See the user's guide of this software.

In the case of a transfer between two SPC400 : first validate the IMPORT-menu on the receiving SPC400, then the EXPORT-menu on the SPC400 from which the transfer is made.

2.2.5.2 IMPORT

A setup transferred by a PC or by another SPC400 is received in the active setup.

If the import destination is an already defined setup, the selection menu will be displayed, providing the possibility to change to another destination. When validating

this choice, the transfer begins, and its advancement is represented on the screen by a bargraph.

At the end of the transfer, SPC400 recalculates the statistics and verifies the validity of the definition and the consistency of the parameters. If an inconsistency is detected, the definition module will be displayed to allow its rectification.

If a transfer has to be done between the SPC400 and a PC, , the XGammes software or an adapted software has to be used on the PC. See the user's guide of this software.

In the case of a transfer between two SPC400 : first validate the IMPORT-menu on the receiving SPC400, then the EXPORT-menu on the SPC400 from which the transfer is made.

Note 1 : in import or export, the serial port parameters are automatically fixed.

Note 2 : import is not available in network version.

2.3 MEASUREMENT MENU

This option provides access to the second module of the program : ***measurements and statistics***. The access to this module will not be possible unless the setup has been correctly defined.

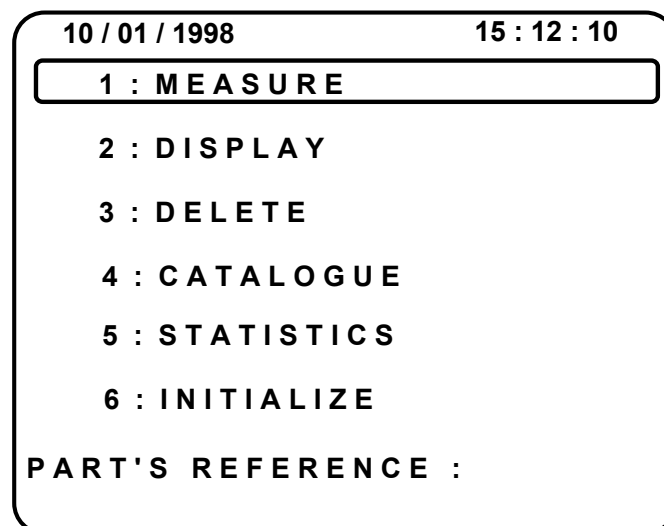

Measurement menu

2.4 CONFIGURATION 1

This option provides access to a "configuration"-menu :

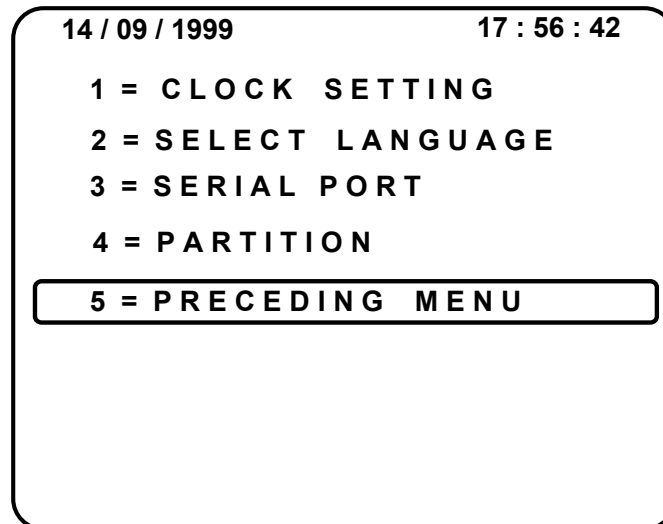

2.4.1 CLOCK SETTING

First hours then minutes are entered.

The same procedure is valid for date, month and year (on 4 digits).

The dates are displayed, printed and transmitted with 4 digits.

2.4.2 SELECT LANGUAGE

Select one of the five languages available (French, English, German, Italian, Spanish) by the arrow-keys, then validate your choice by .

2.4.3 SERIAL PORT

The baud rate of the serial port is set by selecting the appropriate option by the arrow-keys or by entering directly the number corresponding to the desired baud rate. This number is indicated by the help function.

This port can be used for the connection of a serial printer.

The protocol is fixed: 1 start bit, 8 data bits, no parity, 1 stop bit
 XOn/XOff handshaking

In network version of SPC400 (see § 2.2.1), other parameters are proposed :

- network speed = 9600, 19200 or 38400 baud
- type RS232 or RS485
- device number from 00 to 99 (if 00, the network functions are disabled)
- export allowed in the measurement menu
- import allowed from a distant catalogue in the measurement menu

2.4.4 PARTITION

This function enables the partition of each memory page into 1, 2, 4 or 8 setup(s). The partition allows to optimise the use of the memory. The memory space is used dynamically. That is, if the number of characteristics decreases, or if the number of parts per sample decreases, the maximum number of samples will rise.

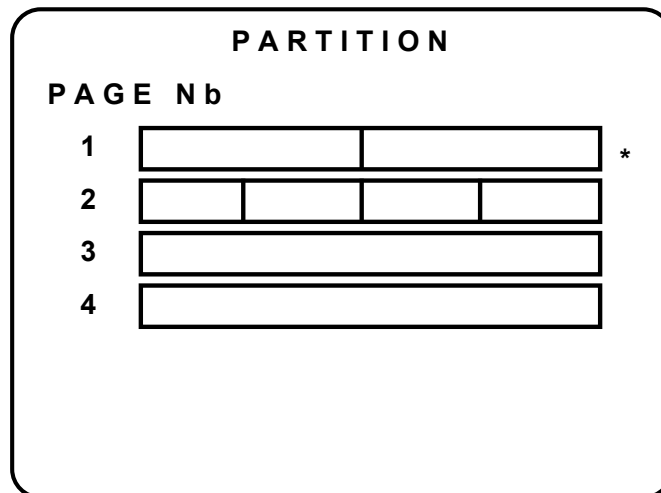

Each page is represented by an horizontal rectangle.

You select a page by the -keys. The selected page is indicated by a (*).

To partition the page, use the B-key and G-key (arrows in alpha mode) :

G () in alpha mode) to increase the number of setups

B () in alpha mode) to decrease the number of setups

Example of handling a page :

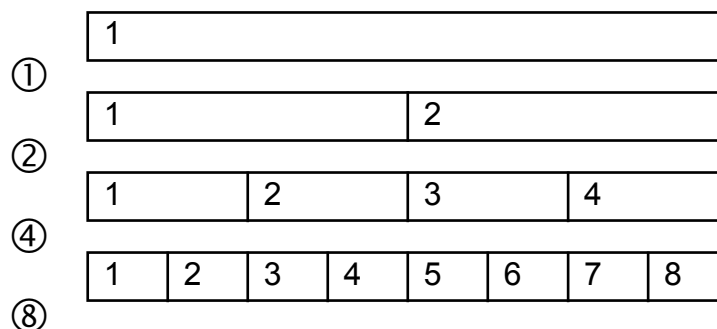

Note :

- When the partitioning of a page is made, all statistics of defined setups will be reset and the undefined setups erased. Hence, it is advisable to export the setups to a PC or to another SPC400 before partitioning in order to avoid the risk of losing data.

- The setups will remain physically in the same place when partitioning. Thus, when the number of setups increases from (4) to (8), setup number 1 will stay at 1 while the

setup 2 will become number 3, and 3 will become 5 and 4 will become 7. Of course, this same thing will happen in the opposite case, that is, when reducing the number of setups, they remain physically in the same place. Thus, when passing from (8) to (2) setups, setup 1 will stay number 1 and only setup 5 from the rest will be preserved as number 2. In this last case, the available memory for setups is increased. However, the statistics of the remaining setups will be reset.

To return to the preceding menu, press .







2.5 CONFIGURATION 2

This option provides access to an other "configuration"-menu :

2.5.1 PROBE TEST

This screen displays the value of a probe in order to check it works or to adjust its position.

The screen « probe test » includes 1, 2 or 3 headings according to the nature of the installed measurement modules. The selected measurement module is indicated by a star (*) on the left hand side of the screen.

To display the different probes of a same module (inductive probes, digital probes or linear encoders, instruments), use the keys   ; to go from one module to the other, the keys   ; to come back to the menu, the key . It can be necessary to press the key  a long time to come back to the menu.

Notes :

1. *The digital probes and linear encoders are displayed with their range (in mm) and their identification number. They work only if they were identified during the entry of the measuring range.*
2. *For the instruments, the ME-key or pressing the « measure (print) » key of the instrument will read the selected instrument (1 to 8).*
3. *The cables for the instruments must absolutely be connected or disconnected when the SPC400 is switched off.*

2.5.2 GRAPHIC MODE

Two different graphic modes are available according to the printer used. The reason is that the command selecting the line feed in graphic mode is not the same for all IBM printers and compatibles. Consequently, an abnormal line spacing can appear on the printout of the control charts. If this is the case, change the graphic mode and try again.

2.5.3 PASSWORD

A password of 10 characters maxi can be defined to forbid all use of SPC400 by an unauthorised person. All the choices from keyboard will only be accessed with this password. This password is particularly useful when the SPC 400 is integrated in a system of automatic control that an unauthorised use can stop.

Warning : don't forget this password.

3. MEASUREMENTS AND STATISTICS

This module is organised around a central menu. It enables measurement, display and printout of results, display and printout of statistics, adjustment of probes and mastering.

3.1 MEASURE	30
3.2 DISPLAY	32
3.2.1 PRODUCTION	33
3.2.2 EVENTS RECORD	33
3.3 DELETE	33
3.4 CATALOGUE	34
3.5 STATISTICS	34
3.5.1 STATISTICS « MACHINE »	35
3.5.2 STATISTICS « PROCESS »	37
3.6 INITIALIZE	41
3.6.1 EXPORT	42
3.6.2 DEFINITION	42
3.6.3 DELETE STAT.	42
3.6.4 INTERVENTIONS	42
3.6.5 PRECEDING MENU	43
3.6.6 BATCH REFERENCE	43
3.6.7 MASTER READING	43

3.1 MEASURE

This second module of the SPC400 is organised around a central menu. It enables measurement, display and printout of results, display and printout of statistics, adjustment of probes and mastering.

11 / 01 / 1998
05 : 32 : 19

1 = MEASURE

2 = DISPLAY

3 = DELETE

4 = CATALOGUE

5 = STATISTICS

6 = INITIALIZE



PART'S REFERENCE:

According to measurements being done, this menu can consist of only the first four lines (when the measurement of a sample is not yet completed).





According to the options included in the definition (several fixtures, presence of measuring instruments, keyboard entry), different cases for measurement will appear. You then have to follow the instructions given on the screen.

- The measurement reading is validated by pressing -key or by using the pedal connected to the back panel of the SPC400.

The first time you press -key, a screen will appear displaying the measuring conditions (characteristic nb, fixture nb, sample nb, etc.). The measurement is done according with the defined triggering mode (see chapter 2.1.8).

- If the definition includes only static measurements by inductive or digital probes, the result is displayed immediately.
- If the definition includes dynamic measurements. A red led lights on the -key, indicating dynamic measurement in progress. This measurement is completed by pressing  once again. The result will then be displayed.

In this case, the measurement of static characteristics is done at light on of the Led.



- If the definition includes measurements made by instruments or entered by keyboard, the SPC400 will prompt you to validate the entry by entering a "O" for OK. To simplify this operation, the SPC400 will be automatically in alpha mode. If you don't agree with the measured value, you have the possibility of retaking the same measurement. To do this, place the cursor on the measurement to be retaken and retake the measurement by pressing -key.
- If the corresponding option was set in the definition, when the measurements are completed, results are printed out or transferred on the serial port. If none of these options were set, a printout or a transfer can be made by the user by pressing  or -key.
- You also have the possibility of making new measurements directly from the screen displaying the results by using the -key.

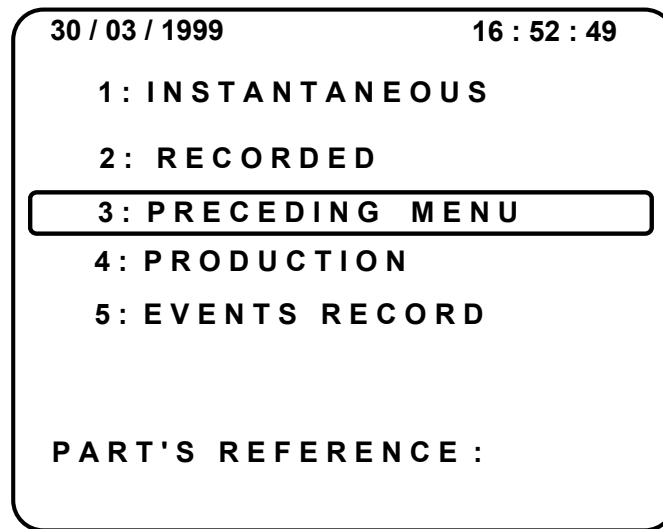

To go back to the main menu or to the statistics (with indication of violations), press .



3.2 DISPLAY





This menu can display *instantaneously* the static or dynamic characteristics, calculated from measurements by inductive or digital probes, with graphic display if measurements are between the tolerances, without taking into account the results of the statistics.

You can go on from one fixture to another by using  -keys.

During display, parts may be measured by pressing -key, then go back to the display by pressing .

This menu can also display the characteristics of already *recorded* parts. The display suggested concerns the last part (or the last sample), but you have the possibility of requesting any other already measured part. To pass from one part to another, use the  -keys.

The measurement recorded can be printed out by pressing . You will then be prompted to indicate the first and the last samples/parts to be printed out. To interrupt the printout or go back to the central menu, press .



This menu also allows to display a summary of the production : numbers of parts and Pareto analysis.

At last, this menu allows to display, if the option 'production' has been chosen in statistics 'machine' or 'none', by rubric 5, the record of the events of production.

3.2.1 PRODUCTION

The rubric « Production » allows to display the total number of parts, the number and percentage of good parts and the number and percentage of bad parts.

A list of numbers of bad characteristics also displayed.

The keys   allow to display the Pareto analysis.



The key  allow to print this summary of production.

3.2.2 EVENTS RECORD

The rubric « Events record » allow to display, if the option 'production' has been chosen in statistics 'machine' or 'none', a summary of the events of production : stops and beginnings of production, SPC400 stops and operator's codification.

The total number of events stored is displayed, followed by a list of the last ten events. The key  allow to print the list of events.

Three fixed codes are defined by the SPC400 (without operator code) : 0 = production stop, 1 = production beginning and 2 = SPC400 power-on.

The bottom line of screen allows to input an event code () of 2 characters and the operator's code (necessary) () of 2 characters. A confirmation with [O] (mode alpha) is asked to avoid errors, because an event can't be deleted.

3.3 DELETE





This function cancels the last measure or the last sample.

A confirmation is requested to avoid erroneous manipulations. Confirm by 'O' (for OK) in alpha mode.

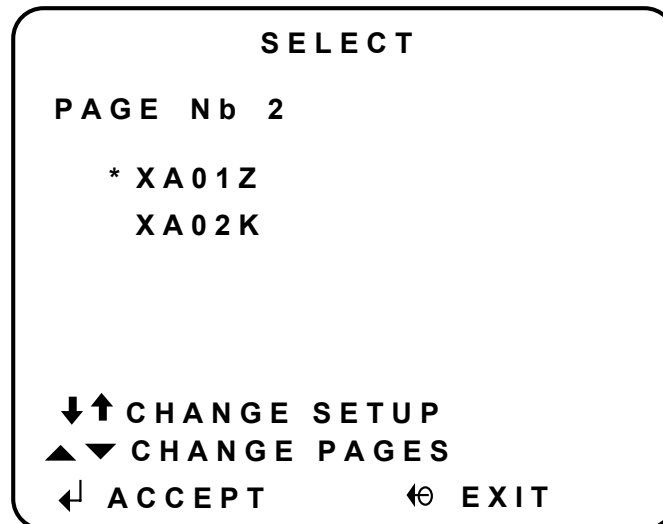
3.4 CATALOGUE

The catalogue function provides access to the catalogue menu.



With this menu, you can select a setup from the list displayed. The selection is done by placing the selection rectangle on the setup of your choice. Use the  -keys to move from one setup to another, and the  -keys to scroll back and forth between pages. Validate your choice by pressing .

If the selected setup is not completely defined or not mastered, a message will indicate "UNDEFINED SETUP". You will then have to select another setup.

The selected setup can be printed out by pressing .

In the network version, a new line «  IMPORT » can appear, if the option has been set (see § 2.4.4), at the bottom of the screen to call a distant catalogue on the server computer.

3.5 STATISTICS





These can be obtained from the central menu, or directly after a measurement, if you chose « 1 = DISPLAY OF STATISTICS » in the first setup definition screen.

You here have the choice between:

1. PROCESS STATISTICS
2. MACHINE STATISTICS

If you choose machine statistics, all measured parts are considered as one unique batch. Accordingly, you have the possibility of displaying and printing out all available kinds of representations for this type of statistics.

3.5.1 STATISTICS « MACHINE »

For each characteristic, four or five numerical and graphical representations are available. Use the  -keys to move from one representation to another, and the  -keys to scroll back and forth between characteristics.

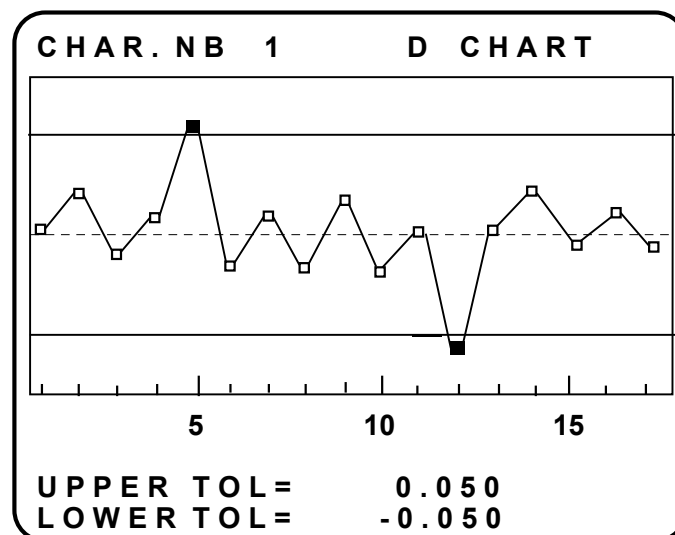

The printout of machine statistics for the displayed characteristic is requested by pressing  in any one of the available screens. The printout will include numerical values and the associated histogram and probability plot.

Screen « Individual values chart »



Each point represents a measurement, graphically positioned with an upper and a lower tolerance (continuous lines) and the average value (dotted line). An empty point indicates that the measured value is within tolerances and a filled point that it is beyond tolerances. The scale at the bottom of the graphic representation indicates the numbers of the parts.

Note : You have the possibility of moving the display along the all the numbers of the measurements made by using :

 to back by 15 parts,  to return to the 1st parts,  to move ahead by 15 parts

Screen « Numerical values »

CHAR. Nb 1		
UPPER TOL=		0.100
NOMINAL =		14.500
LOWERTOL=		-0.100
X BAR =		14.5044
STAND DEV=		0.0124
MAXIMUM =		14.5090
MINIMUM =		14.4940
RANGE =		0.0130
C m =		2.688
C m k =		1.380
NB PARTS =		50
DEFECT. =		0

Note : The calculated values are displayed with an additional decimal with regard to the number of decimals requested in the definition menu.

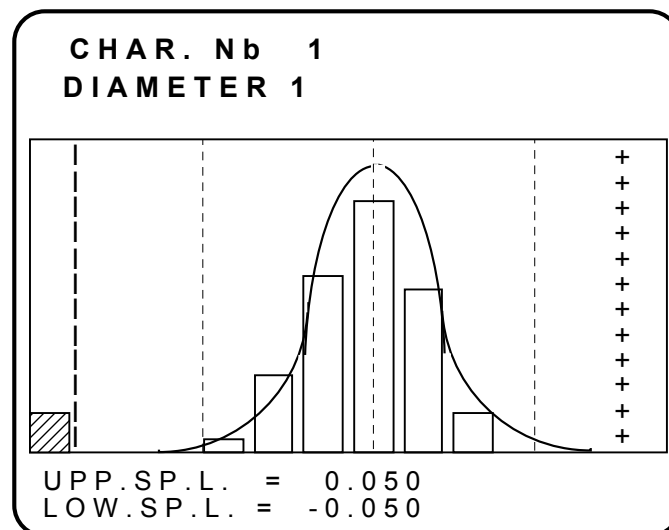
Screen « Histogram »

The histogram is represented with 20 classes within tolerances, and two classes beyond tolerances. These two classes include all values respectively beyond upper and lower tolerances (their width is undefined).

A normal distribution curve (Gauss curve) is superposed on the histogram. This curve enables an appreciation of the normality of the measured sample.

A fine dotted line indicates the average, and two other dotted lines further out indicates the average $\pm 4\sigma$.

Screen « Probability plot »

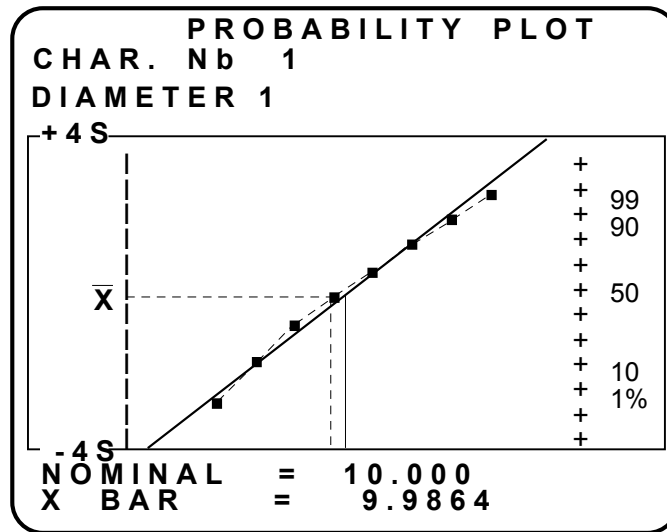

This graphic represents the cumulated frequencies of each of the histogram classes. If the sample presents a normal distribution, the points are plotted in line with the theoretical straight line. The graphic is limited on the right and on the left by the limits of tolerances, and on the top and at the bottom by the average $\pm 4\sigma$.

Screen « Pareto Analysis »

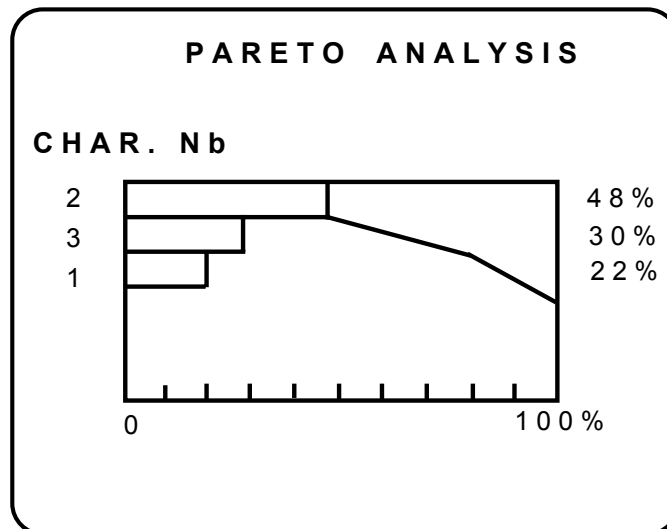

This last screen, the Pareto analysis, is displayed on condition that at least one measured value is beyond tolerances. It represents, in falling order, the percentage of the different characteristics responsible for the rejection of parts.

3.5.2 STATISTICS « PROCESS »

For each characteristic, the following graphic screens are displayed one after the other :

- chart of averages
- chart of standard deviations (or ranges)
- list of the violations (trends), if at least one of the eight possible is validated
- chart of averages if the option was validated either with the $\pm 3\sigma$ or with the ranges (see chapter 2.1.2.1 : MIXED CHART).
- screen with numerical values

A printout of process statistics is made for the currently displayed characteristic by pressing  in any one of the screens. The printout concerns the numerical values and a plot of averages with, according to selected options, the dispersion for $\pm 3\sigma$ or the range of each sample. You will be prompted for the numbers of the first and the last samples to be printed out.

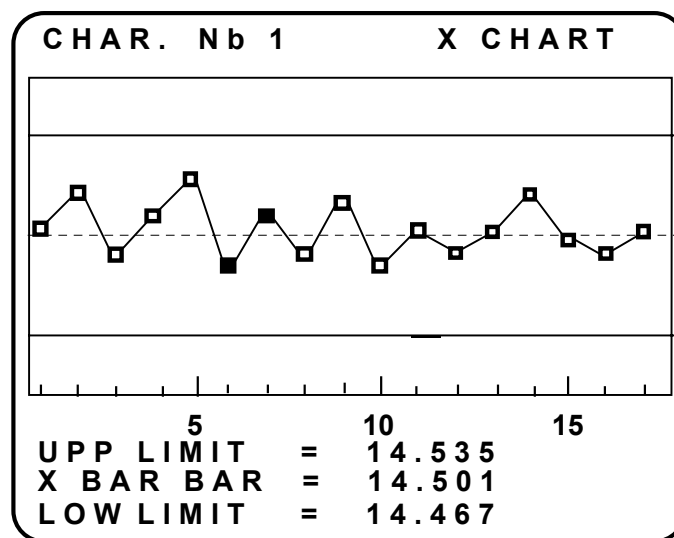

Screen « Chart of Averages »



Each point represents the average value of a sample, graphically positioned with an upper and a lower tolerance (continuous lines) and the average value (dotted line). A filled point shows a violation, either on \bar{X} or on σ/R (on the printer, a filled point means « beyond tolerances ») ; otherwise the point is empty. The scale at the bottom of the graphic representation indicates the numbers of the samples

Note : The control limits can either be calculated on the last 25 samples, or be fixed by the user.

You have the possibility of moving the display along the all the numbers of the measurements made by using :

 to back by 15 parts,  to return to the 1st parts,  to move ahead by 15 parts

Screen « Chart of standard deviations or ranges »

According to the choice of chart to be displayed (see chapter 2.1.2.1 DEFINITION - CHART), you will obtain either the chart of standard deviations (S-Chart) or the chart of ranges (R-Chart).

S-CHART : chart of standard deviations :

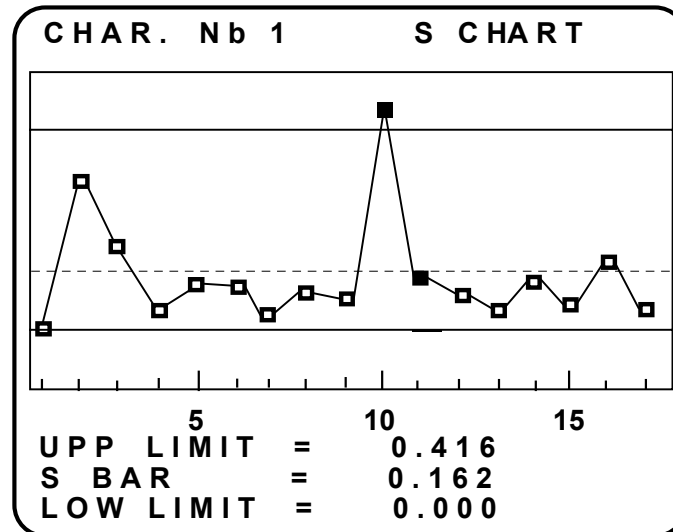

Each point represents the standard deviation of a sample, graphically positioned with control limits (continuous line) and the average of the standard deviations (fine dotted line).

R-CHART : chart of ranges :

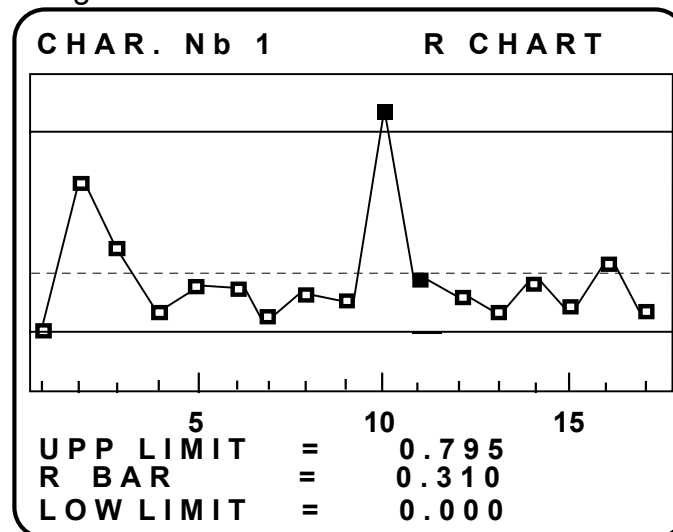

Each point represents the range of a sample, graphically positioned with control limits (continuous line) and the average of the ranges (fine dotted line).

A filled point shows a violation, either on \bar{X} or on σ/R (on the printer, a filled point means « beyond tolerances ») ; otherwise the point is empty.

Screen « VIOLATIONS »

If at least one of the eight detectable violations (see § 2.1.3) is validated and even though no violation was detected, the chart of violations is displayed.

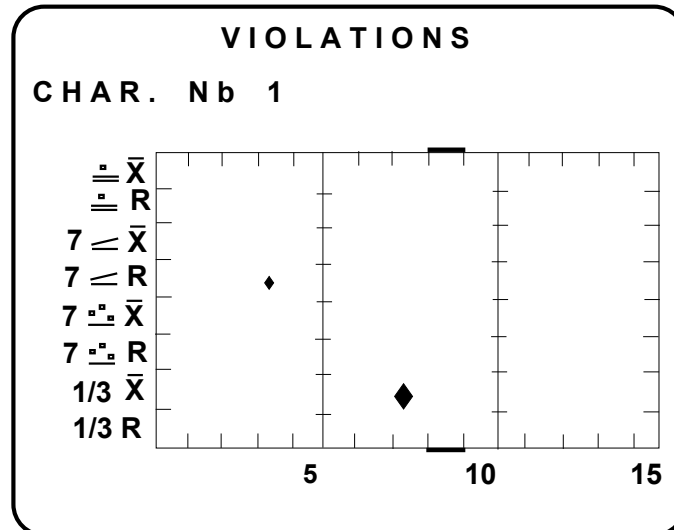

The list of the types of violations (vertical on the left) indicates only the violations validated in the definition of the measuring range.
 The symbols '▼' or '▲' show if the violation is lower or upper.
 The 2 horizontal lines on the scales (high and low) indicate the number of the last sample which was made.

In this example :

- a violation of « descending series on the range » type was detected in sample 4
- an upper violation of « central tiers on average» type was detected in sample 8
- the last sample measured is the number 9

Screen « Mixed chart »

According to the choice of chart to be displayed (see chapter 2.1.2.1 DEFINITION - CHART) and according to whether the mixed chart was authorised, you will obtain the chart of averages with either standard deviations or ranges.

6S-CHART : « chart of averages and $\pm 3\sigma$ » :

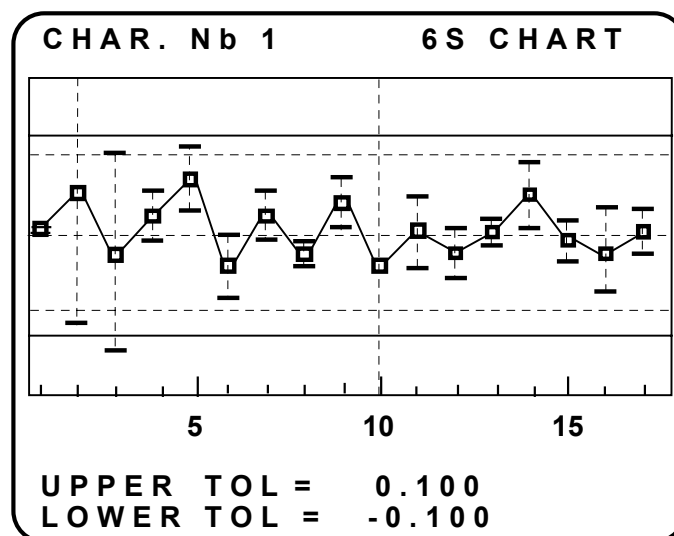

Each point represents the average of a sample, graphically positioned with limits of tolerances (continuous lines) and the average of the averages values (fine dotted line) as well as the control limits for the average (dotted line). The vertical dotted lines represent the $\pm 3\sigma$ of a sample.

XR-CHART :

If a chart of ranges was selected, the screen will be the same except for the vertical lines which will indicate the range between the maximum and the minimum measured values of the sample.

Screen « Numerical values »

CHAR. Nb	1
PART/SAMPLE=	3
NOMINAL =	14.500
UPP.TOL. =	0.100
LOW.TOL. =	-0.100
X-BAR BAR =	14.5012
UPP.LIM. =	14.535
LOW.LIM. =	14.467
RANGE BAR=	0.416
UPP.LIM. =	0.162
LOW.LIM. =	0.000
Cp	= 2.688
Cpk	= 1.380

According to the chart selected, you will obtain the numerical values of the average and the limits of the standard deviations or of the ranges.

Note : the calculated values are displayed with an additional decimal with regard to the number of decimals requested in the definition menu.

3.6 INITIALIZE

This option provides access to a sub-menu including seven options:

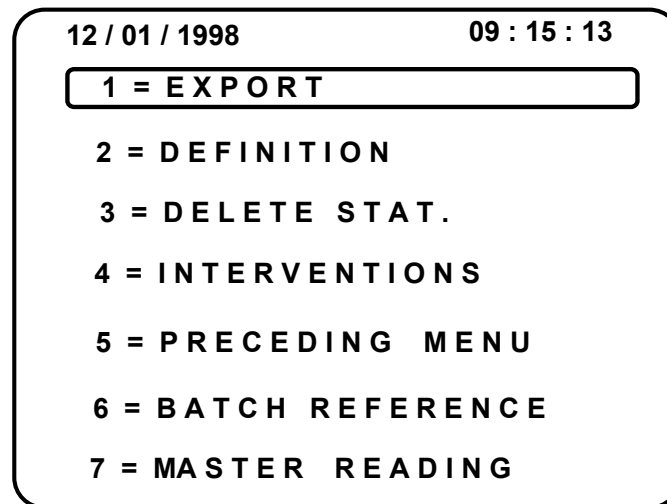

3.6.1 EXPORT

Export of data implies the transfer of the full contents of the setup : definition, measures and, when involved, readings, dates, corrective actions, causes of intervention, trends, etc.. You thus have the possibility of recording a setup on the PC and re-import it later, retaking the statistics at the same point.

The active setup is transferred to a PC or to another SPC400.

If a transfer has to be done between the SPC400 and a PC, an adapted software has to be used on the PC. See the user's guide of this software.

In the case of a transfer between two SPC400 : first validate the IMPORT-menu on the receiving SPC400, then the EXPORT-menu on the SPC400 from which the transfer is made.

Note : not available in the network version.

3.6.2 DEFINITION

Provides access to the module « **definition and configuration** ».

When prompted for the "PASSWORD", enter "DEF" (in alpha-mode), then validate by pressing .

3.6.3 DELETE STAT.

Reset of statistics corresponding to the active setup.

A confirmation is requested to avoid erroneous manipulations. Confirm by [O] (for OK) in alpha-mode.

3.6.4 INTERVENTIONS

For "causes of intervention" and "corrective actions", you have the possibility to define codes that will be displayed on graphics on the screen and on printout. These codes are chosen by the user and appear on graphics only for information. The codes can be chosen freely among available letters and numbers on the keyboard. A code consists of one character, such as "A" for adjustment" and "S" for sorting, etc..

Note : the codes by default are space-characters. Consequently, to enter a code, you first have to erase the space code by pressing , to be able to replace it by the desired code.

3.6.5 PRECEDING MENU

Returns to the preceding menu.

3.6.6 BATCH REFERENCE

Alphanumerical text including a maximum of 19 characters appearing in the head-line of printed documents under the part's reference.



If, for example, you are working with machine statistics, in measurement characteristic by characteristic, and have yet not performed any measurement, you can indicate the number of parts that are to be measured in this batch.

3.6.7 MASTER READING

If a setup includes measurements made by inductive probes the SPC400 need a reference to be able to assess measurements correctly. This is where the « *master reading* » is needed.

You will be prompted to do a master reading before the first measurement. If automatic mastering was set in the setup definition, you will also be prompted to do a master reading each time the set number of measurements or the time between two master readings is attained. Moreover, a « master reading » can be done any time the user finds it necessary.

According to the options set in the definition (stand by test, repetition test, number of fixtures), the master reading will be performed differently. You then have to follow the instructions provided on the screen.

- In all cases the master is positioned, and the reading validated by -key.
- If stand by test was activated, first remove the master, then validate by pressing -key without the master.
- If repetition test was activated, first remove the master, then put it back in position and validate by pressing -key.

If the stand by test and the repetition test are rejected during the master reading, an error message will notify the type of error.

4. EXAMPLES OF PROBE COMBINATIONS

4.1 SIMPLE MEASUREMENTS WITH ONE PROBE

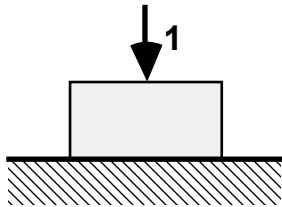

C(1)

Thickness

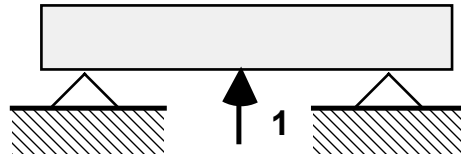

C(1)

Flatness

4.2 COMBINED MEASUREMENTS WITH TWO PROBES

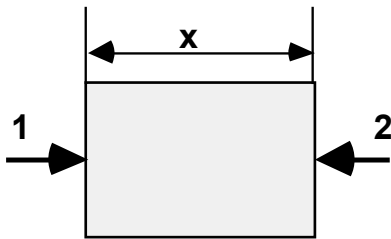

C(1)+C(2)

Thickness or external diameter

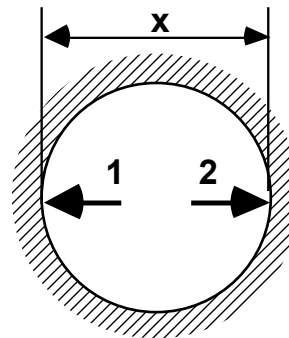

-C(1)-C(2)

Width or internal diameter

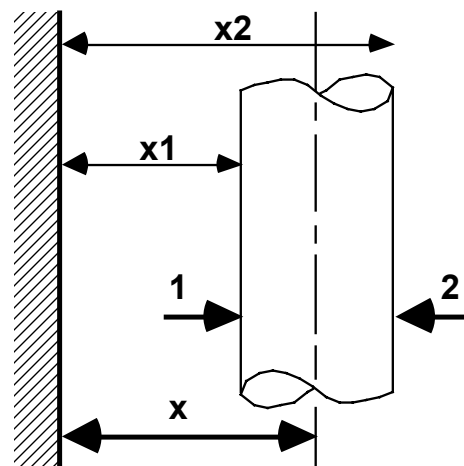
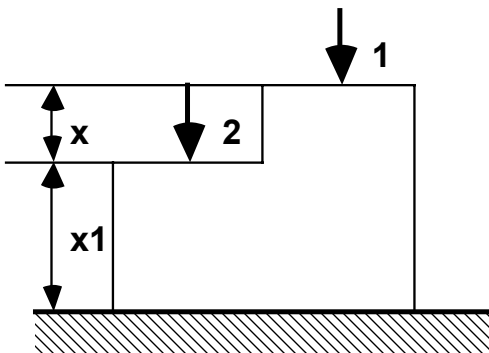

$X_1 = C(1)$
 $X_2 = C(2)$
 $X = C(1) - C(2)$

$X_1 = C(1)$
 $X_2 = C(2)$
 $X = (C(1) - C(2)) / 2$

Thrust

Position

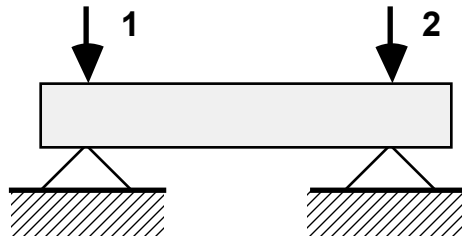

Parallelism

$X = C(1) - C(2)$

4.3 COMBINED MEASUREMENTS WITH THREE PROBES

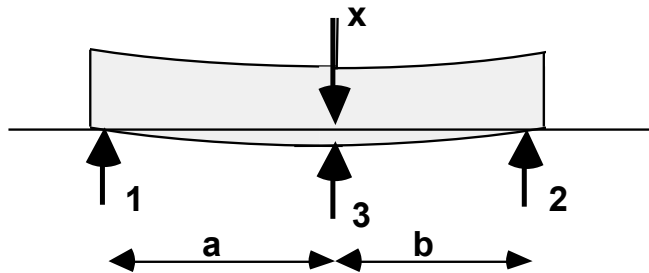

Straightness

$X = -C(1) * (b / (a + b)) - C(2) * (a / (a + b)) + C(3)$

4.4 COMBINED MEASUREMENTS WITH FOUR PROBES

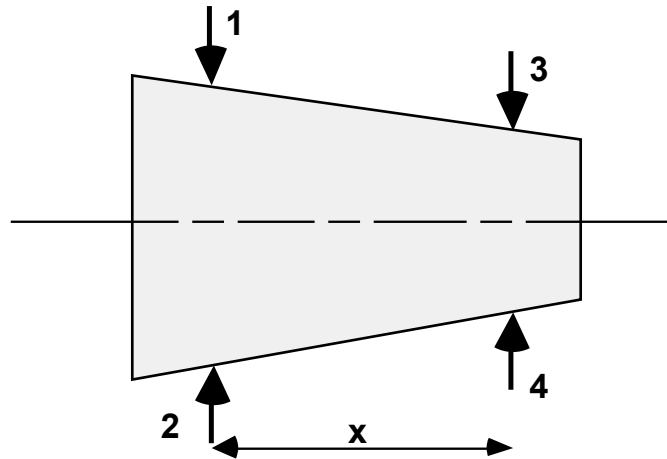

Conicity

$$X = C(1) + C(2) - C(3) - C(4)$$

$$dV = (C(1) + C(2) - C(3) - C(4)) / a$$

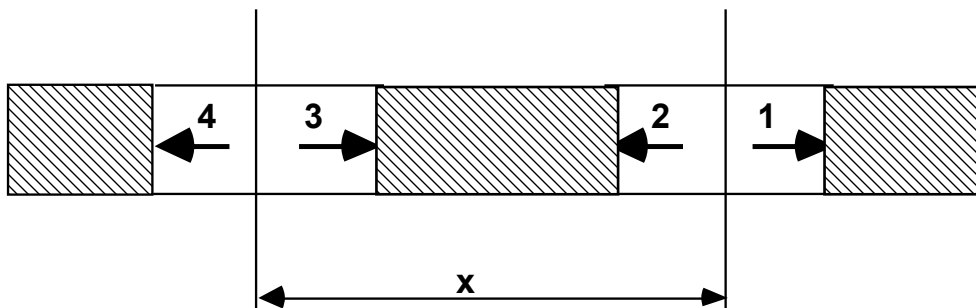

Distance between axes

$$X = (-C(1) + C(2) + C(3) - C(4)) / 2$$

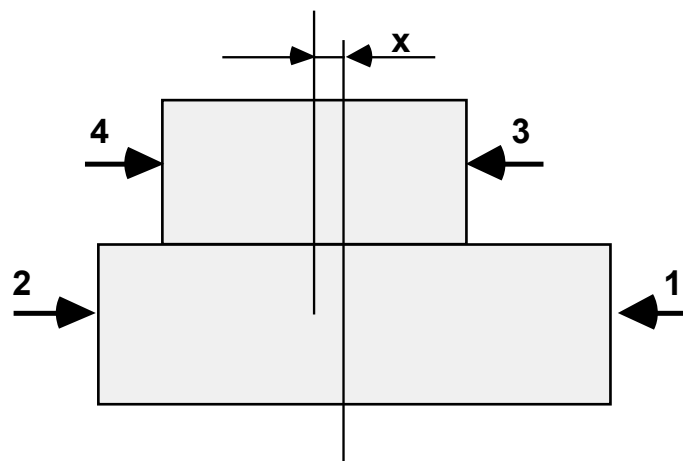

Concentricity

$$X = (C(1) - C(2) - C(3) + C(4)) / 2$$

5. TABLE OF CONSTANTS AND FORMULAS

5.1 Used symbols

n	number of parts in a sample
s	standard deviation of a sample
\bar{s}	average value of the standard deviation of several samples
R	range of a sample
\bar{R}	average value of the ranges of several samples
\bar{X}	(x bar) average value of a sample
$\bar{\bar{X}}$	(x double bar) average of the average values of several samples
UCL	upper control limit
LCL	lower control limit

5.2 \bar{X} - and S-Charts

Graphic illustration of averages (\bar{X}) Graphic illustration of standard deviations (S)

Sample size	Coefficient for control limits	Divisor for estimation of standard dev.	Coefficients for control limits	
n	A3	C4	B3	B4
2	2,659	0,7979	-	3,267
3	1,954	0,8862	-	2,568
4	1,628	0,9213	-	2,266
5	1,427	0,9400	-	2,089
6	1,287	0,9515	0,030	1,970
7	1,182	0,9594	0,118	1,882
8	1,099	0,9650	0,185	1,815
9	1,032	0,9693	0,239	1,761
10	0,975	0,9727	0,284	1,716
11	0,927	0,9754	0,321	1,679
12	0,886	0,9776	0,354	1,646
13	0,850	0,9794	0,382	1,618
14	0,817	0,9810	0,406	1,594
15	0,789	0,9823	0,428	1,572
16	0,763	0,9835	0,448	1,552
17	0,739	0,9845	0,466	1,534
18	0,718	0,9854	0,482	1,518
19	0,698	0,9862	0,497	1,503
20	0,680	0,9869	0,510	1,490
21	0,663	0,9876	0,523	1,477
22	0,647	0,9882	0,534	1,466
23	0,633	0,9887	0,545	1,455
24	0,619	0,9892	0,555	1,445
25	0,606	0,9896	0,565	1,435

$$UCL\bar{x}, LCL\bar{x} = \bar{\bar{x}} \pm A3\bar{s}$$

$$UCLs = B4\bar{s}$$

Estimation of standard deviation

$$LCLs = B3\bar{s}$$

$$\hat{s} = \frac{\bar{s}}{C4}$$

5.3 \bar{X} - and R-Charts

Graphic illustration of averages (\bar{X}) Graphic illustration of ranges (R)

Sample size	Coefficient for control limits	Divisor for estimation of standard dev.	Coefficients for control limits	
			D3	D4
n	A2	d2		
2	1,880	1,128	-	3,267
3	1,023	1,693	-	2,574
4	0,729	2,059	-	2,282
5	0,577	2,326	-	2,114
6	0,483	2,534	-	2,004
7	0,419	2,704	0,076	1,924
8	0,373	2,847	0,136	1,864
9	0,337	2,970	0,184	1,816
10	0,308	3,078	0,223	1,777
11	0,285	3,173	0,256	1,744
12	0,266	3,258	0,283	1,717
13	0,249	3,336	0,307	1,693
14	0,235	3,407	0,328	1,672
15	0,223	3,472	0,347	1,653
16	0,212	3,532	0,363	1,637
17	0,203	3,588	0,378	1,622
18	0,194	3,640	0,391	1,608
19	0,187	3,689	0,403	1,597
20	0,180	3,735	0,415	1,585
21	0,173	3,778	0,425	1,575
22	0,167	3,819	0,434	1,566
23	0,162	3,858	0,443	1,557
24	0,157	3,895	0,451	1,548
25	0,153	3,931	0,459	1,541

$$UCL_{\bar{X}}, LCL_{\bar{X}} = \bar{\bar{x}} \pm A2\bar{R}$$

$$UCLs = D4\bar{R}$$

Estimation of standard deviation

$$LCLs = D3\bar{R}$$

$$\hat{\sigma} = \frac{\bar{R}}{d2}$$

5.4 Formulas

Average value

$$\bar{\bar{x}} = \frac{X_1 + X_2 + \dots + X_n}{n}$$

Average of average values

$$\bar{\bar{X}} = \frac{\bar{X}_1 + \bar{X}_2 + \dots + \bar{X}_m}{m}$$

Standard deviation of the sample

$$s = \sqrt{\frac{\sum X_i^2 - \frac{1}{n}(\sum X_i)^2}{n-1}}$$

Average value of the standard deviations

$$\bar{s} = \frac{S_1 + S_2 + \dots + S_m}{m}$$

5.5 Capability indexes

Machine Capability

$$C_m = \frac{\text{specified tolerance}}{6\hat{\sigma}}$$

Cmk = minimum of: $\frac{\text{upper specification limit} - \bar{X}}{3\hat{\sigma}}$ and $\frac{\bar{X} - \text{lower specification limit}}{3\hat{\sigma}}$

Process Capability

$$C_p = \frac{\text{specified tolerance}}{6\hat{\sigma}}$$

Cpk = minimum of: $\frac{\text{upper specification limit} - \bar{X}}{3\hat{\sigma}}$ and $\frac{\bar{X} - \text{lower specification limit}}{3\hat{\sigma}}$

TABLE OF CONTENTS

THE SECTIONS **1**

1. INTRODUCTION **1**

1.1 PRESENTATION OF THE SPC400	2
1.2 PRECAUTIONS	2
1.3 FEATURES.....	3
1.4 FRONT PANEL.....	4
1.5 THE KEYBOARD.....	5
1.6 THE SCREEN.....	6
1.7 THE SERIAL PORT.....	6
1.7.1 « SERIAL PORT » CONNECTOR PIN-OUT	6
1.7.2 THE OPTICAL READER	7
1.8 PEDAL ENTRY	7
1.9 STRUCTURE OF THE SPC400 SOFTWARE.....	8

2. DEFINITION AND CONFIGURATION **9**

2.1 DEFINE.....	10
2.1.1 GENERAL DEFINITION SCREEN.....	11
2.1.2 SELECT OPTIONS (1).....	12
2.1.3 DEFINITION OF VIOLATIONS.....	12
2.1.4 CHARACTERISTICS DEFINITION.....	13
2.1.5 SELECT OPTIONS (2).....	18
2.1.6 MASTER READING	18
2.1.7 DEFINITION - NBR OF FIXTURES	20
2.1.8 AUTOMATION SEQUENCES	20
2.1.9 MEASUREMENT TRIGGER.....	20
2.1.10 IDENTIFICATION OF DIGITAL PROBES.....	22
2.2 CATALOGUE.....	23
2.2.1 SELECT	23
2.2.2 PRINT	23
2.2.3 DUPLICATE	24
2.2.4 DELETE	24
2.2.5 IMPORT-EXPORT.....	24
2.3 MEASUREMENT MENU	25
2.4 CONFIGURATION 1.....	26
2.4.1 CLOCK SETTING.....	26
2.4.2 SELECT LANGUAGE.....	26
2.4.3 SERIAL PORT.....	26
2.4.4 PARTITION	27
2.5 CONFIGURATION 2.....	28
2.5.1 PROBE TEST.....	28
2.5.2 GRAPHIC MODE	28
2.5.3 PASSWORD	28

3. MEASUREMENTS AND STATISTICS	30
3.1 MEASURE	30
3.2 DISPLAY	32
3.2.1 PRODUCTION	33
3.2.2 EVENTS RECORD	33
3.3 DELETE	33
3.4 CATALOGUE	34
3.5 STATISTICS	34
3.5.1 STATISTICS « MACHINE »	35
3.5.2 STATISTICS « PROCESS »	37
3.6 INITIALIZE	41
3.6.1 EXPORT	42
3.6.2 DEFINITION	42
3.6.3 DELETE STAT.	42
3.6.4 INTERVENTIONS	42
3.6.5 PRECEDING MENU	43
3.6.6 BATCH REFERENCE	43
3.6.7 MASTER READING	43
4. EXAMPLES OF PROBE COMBINATIONS	44
4.1 SIMPLE MEASUREMENTS WITH ONE PROBE	44
4.2 COMBINED MEASUREMENTS WITH TWO PROBES	44
4.3 COMBINED MEASUREMENTS WITH THREE PROBES	45
4.4 COMBINED MEASUREMENTS WITH FOUR PROBES	45
5. TABLE OF CONSTANTS AND FORMULAS	47
5.1 USED SYMBOLS	47
5.2 \bar{X} - AND S-CHARTS	48
5.3 \bar{X} - AND R-CHARTS	49
5.4 FORMULAS	49
5.5 CAPABILITY INDEXES	50
TABLE OF CONTENTS	51
